

# DESIGNCON<sup>®</sup> 2014

## Relating COM to Familiar S-Parameter Parametric to Assist 25Gbps System Design

Xiaoqing Dong and Moore Mo  
Huawei Technologies



Fangyi Rao  
Agilent Technologies



Agilent Technologies

Wenyi Jin and Geoff Zhang  
Xilinx Inc.



January 28-31, 2014 | Santa Clara Convention Center | Santa Clara, CA



# Outline

- High speed serial link channel specification overview
- Introduction to Channel Operating Margin (COM)
- COM computation for 25Gbps sample channels
- Time domain simulation for 25Gbps sample channels
- Comparison of COM result with TD simulations
- Measured data from some 25Gbps system links
- Individual impact on COM: loss, reflection, and crosstalk
- Proposed channel template for 25Gbps system design
- Conclusions

# System Engineers Wish List

- A high speed system is designed based on information such as data rate, channel lengths, temperature range, channel density, desired connectors, pin maps, coding scheme, and so on.
- These inputs can be translated into system link s-parameter characteristics, such as IL, RL, ILD, PSXT, and ICR/ICN.
- While data rate is relatively lower (10Gbps and below) , system performance margin is usually high. A working system can be designed relying on basic assumptions of a SerDes device.
- When data rate goes beyond 15Gbps, this luxury is no longer available. If a system is designed strictly based on some standard, the system could be either too costly and the final product has no market, or the system simply cannot be manufactured to meet the product specifications.



# SerDes Vendor's Dilemma

- On the SerDes vendor's side, if there are different specifications then the design work becomes a guess game.
  - If the SerDes is designed to meet the lower spec, it has the advantage in complexity, power, and size. However, if the device cannot handle a given system with desired performance, this SerDes will unlikely be selected.
  - If the designed SerDes beats the hardest spec, usually with extra power and area, while the equipment manufacturer designed a system to meet the easier standard (without the knowledge that a stronger SerDes is available), a different problem is created. This SerDes will unlikely be used, either.
- SerDes is not a simple measure of how much loss it can drive
  - A SerDes that can handle a “difficult channel” does not always mean it can cope with an “easy channel”;
  - A SerDes that can deal with a smooth channel may fail with a bumpy one;
  - A SerDes may behave drastically differently for different data patterns.



# High Speed Channel Specification Overview

# 10GBase-KR Standard

- 10GBase-KR specifies a series of masks intending to provide system engineers insight at the early stage of design whether an architected system meets the BER target ( $1e-12$  in the KR standard), without knowing a specific SerDes IP performance.
- Among the masks IL and ICR are the two most often used, as they are recognized in practical applications as the dominant factors in determining system BER.
- ILD, RL and Fitted Attenuation are also specified for more in-depth evaluation such that link performance is more under control.
- The straightforward and easy-to-use nature of this standard is perhaps the often referenced today. However, we should understand that
  - Passing 10GBase-KR masks do not always mean meeting the BER;
  - BER= $1e-12$  target no longer suffices to meet most system requirements.



# 10GBase-KR Standard Masks

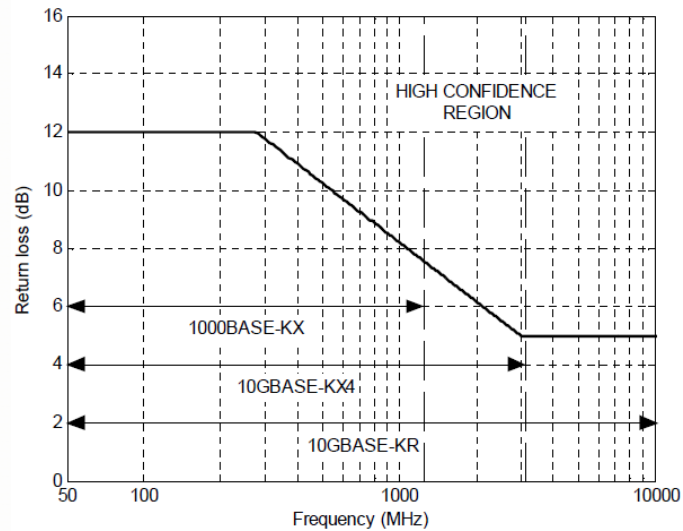
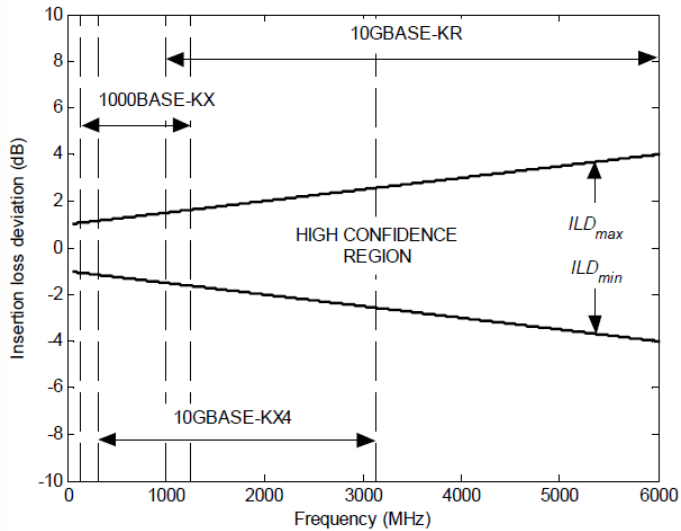
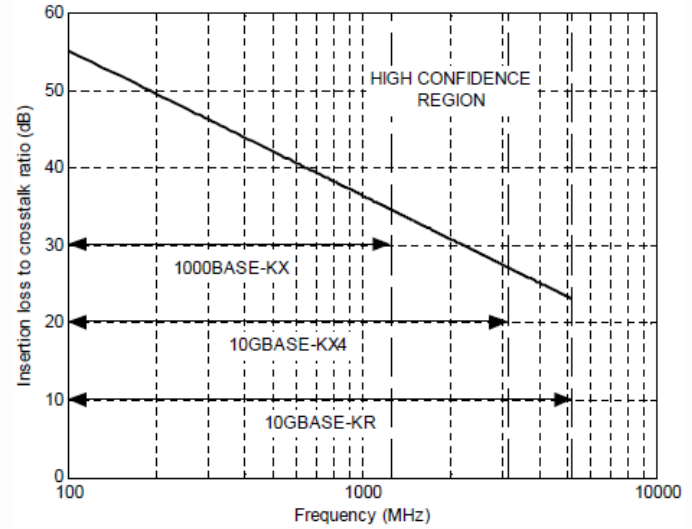
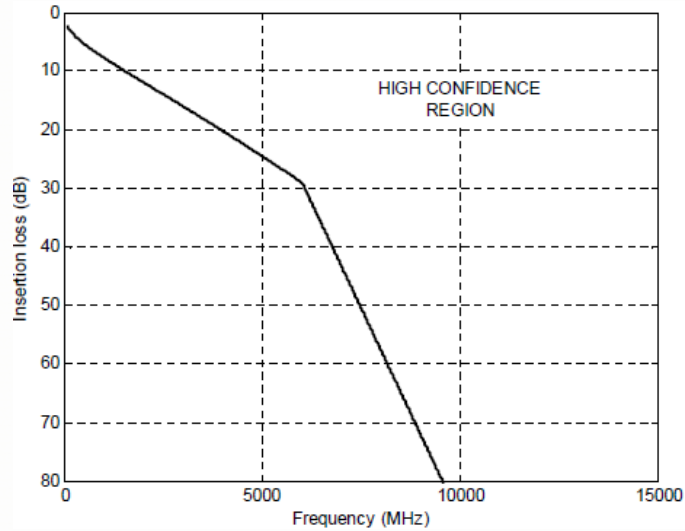

# CEI-11G Standard

- The CEI-11G standard uses different approaches to specify channel compliance.
  - CEI-11G-LR/MR specifies a through channel and associated dominant crosstalk channels. They are compliant if for both the specified reference TX and RX, the signal conforms to the defined eye mask and does not exceed the defined jitter using the StatEye method.
- StatEye method can further incorporate TX and RX behavioral models to represent better real applications.

## CEI11G LR receiver eye mask and jitter spec

Parameter	Symbol	Max	Units
Eye mask	R_X1	0.2625	UI
Eye mask	R_Y1	50	mV
Correlated Bounded High Probability Jitter, pre-equalizer	R_CBHPJ	0.40	UIpp
Correlated Bounded High Probability Jitter, post-equalizer	R_CBHPJ	0.10	UIpp
Uncorrelated Bounded High Probability Jitter	R_UBHPJ	0.15	UIpp
Uncorrelated Unbounded Gaussian Jitter	R_UUGJ	0.15	UIpp
Quality of signal (SNR in real number)	Q	7.94	

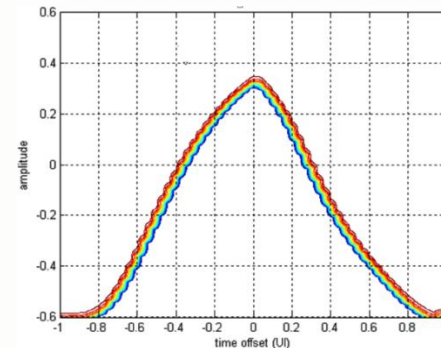

- StatEye specifies several different SerDes architectures according to the standard CEI applications, but they are never a substitute of device level time domain simulations.
- StatEye is a good way compared to KR masks to assess SerDes behavior. However, it is not direct for users. It is recognized as too stringent on channels in most applications.



# OIF-CEI 25G Standard

- The OIF-CEI 25G standard uses similar ‘masks’ to specify channels as in 10GBase-KR, except the exact specifics for the IL mask, Fitted IL, ILD, and RL.
  - In addition, ICN (integrated crosstalk noise) is defined instead of ICR.
- CEI-25G LR is too strict for system companies, thus making the masks lack of practical use.
  - The OIF-CEI 25G puts the maximum allowable link insertion loss to 25dB at the Nyquist frequency.
    - This is impossible for network products, given that the link lengths have to be maintained more than 30”, or even approaching 40”.
  - To specify  $ICN < 1mV_{rms}$  from aggregated crosstalk noise is unrealistic for most applications, based on system studies using today’s connectors by industry leading vendors.
    - There could be at least 8 dominant aggressors. In addition, link crosstalk is not only contributed by connectors, but also from via coupling, etc. Thus, 1mV<sub>rms</sub> is simply too tight for practical system links.

# OIF-CEI 25G Standard (Con't)

- Meanwhile, it has been observed that available 25G SerDes chips from multiple vendors are showing stronger capabilities than the OIF-CEI 25G LR standard.
  - There are 25G SerDes IPs showing capabilities of  $IL > 30\text{dB}$  and  $ICN > 4\text{mVrms}$  simultaneously, based on test data from several prototype systems.
  - Thus, people turn to more daring approaches, based on empirical experience in defining the system architecture and designing the system.
- It is difficult for SerDes vendors to know in advance system manufacturers link performance.
- It is also difficult for system manufacturers to know SerDes capabilities in advance for better link budgeting.
  - Simulation models and test chips are usually available after system definition is completed and system design is already started.

# OIF-CEI 25G Standard Masks

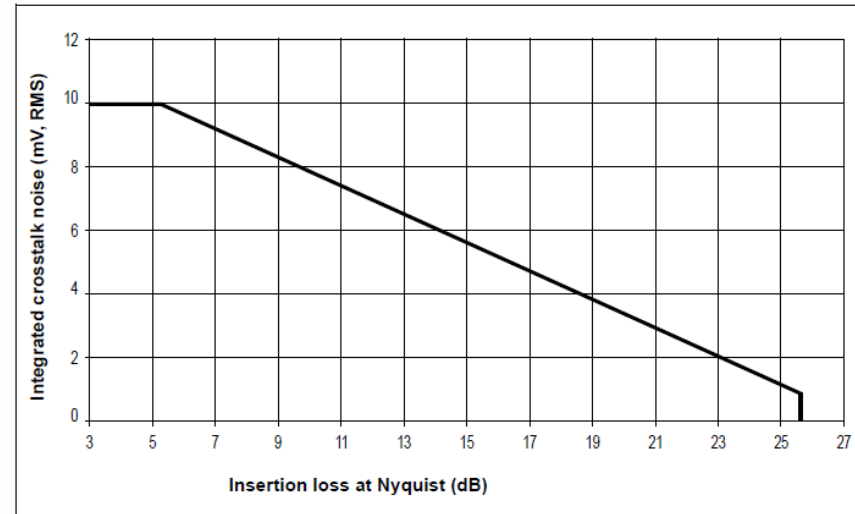
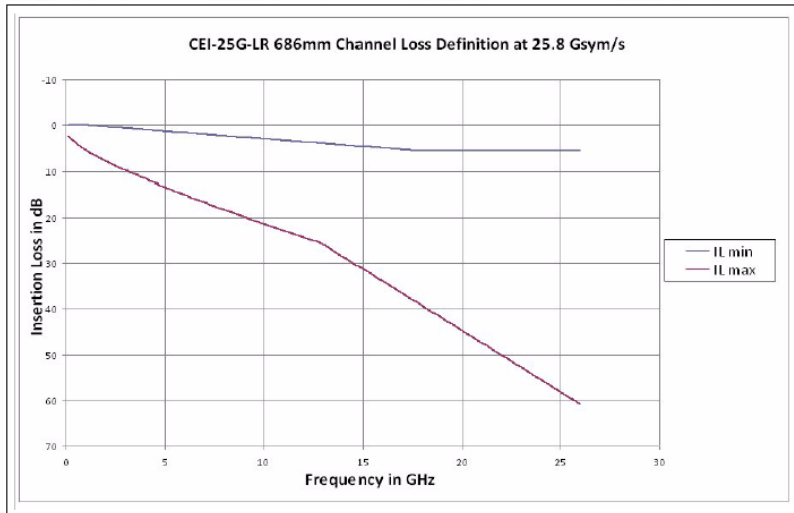

- Except for the IL and ICN masks, ILD is calculated as time domain noise and RL is specified using the following expression:

Channel Return Loss shall be bounded by:

$$ILD_{rms} = \sqrt{\frac{\sum W(f) \times ILD(f)^2}{N}}$$

- $RL(f) \geq 12 \text{ dB}$  for  $f_{min} < f \leq f_b/4$
- $RL(f) \geq 12 \text{ dB} - 15 \text{ Log}_{10}(4f/f_b)$  for  $f_b/4 < f < f_b$



# IEEE 802.3bj Standard

- The IEEE802.3bj standard uses the same definitions of IL, ICN, ILD, etc. as in the CEI-25G LR standard, but not as masks. They are only used as references.

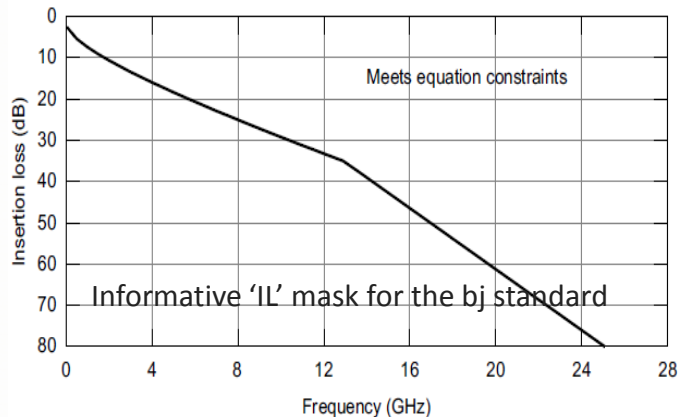

- IL reference when utilizing the RS(255,239) to get target detector error ratio of  $1e-12$ .
  - It is assumed 30dB be achieved without the FEC.
- SerDes driving capability 'boundaries' shall be studied for given applications, as FEC's benefit in dB loss compensation is different for different systems (channel and device specifics play a role as well).
  - Channel 'mask' becomes obscure as FEC benefit and crosstalk conditions are neither clear nor applicable to every system links.
  - COM (Channel Operating margin) is the final FOM (figure of merit) relating a link channel design to the target BER.

(COM background will be covered in the next section.)



# Introduction to COM

## (Channel Operating Margin)

# What is COM and Why Using it?

*“These calculations are expected to be fast and efficient, utilizing transmitter and receiver specification parameters. This is in contrast to simulations requiring high quality device models.*

*The intent of COM is to qualify a channel in the context of a specification, rather than a simulation qualification for a specific design. The latter has the potential to tune margin for a particular design. This is not the intent of COM.”*

Quote from [4]: Richard Mellitz, “Channel Operating Margin (COM): Evolution of Channel Specifications for 25 Gbps and Beyond”, DesignCon 2013,



# Where is COM Different?

- COM is based on data eye formalization.
- COM has assumed a practical TX and RX equalization capability.
  - TX de-emphasis and RX CTLE are jointly optimized.
  - COM defines ideal n-tap DFE.
- COM has defined detailed calculation of crosstalk and ISI distributions, rather than simply treating them as Gaussian distribution.
- COM does not consider CDR timing, and allows some margin in the computed result.

# COM Basics

- COM is a FOM that relates the ratio of calculated signal amplitude ( $A_s$ ) to the calculated noise amplitude ( $A_{ni}$ )

$$COM = 20 * \log_{10}(A_s / A_{ni})$$

- Channels that are compatible with the model of operation shall meet this COM requirement with  $DER_0$  set to the desired target.

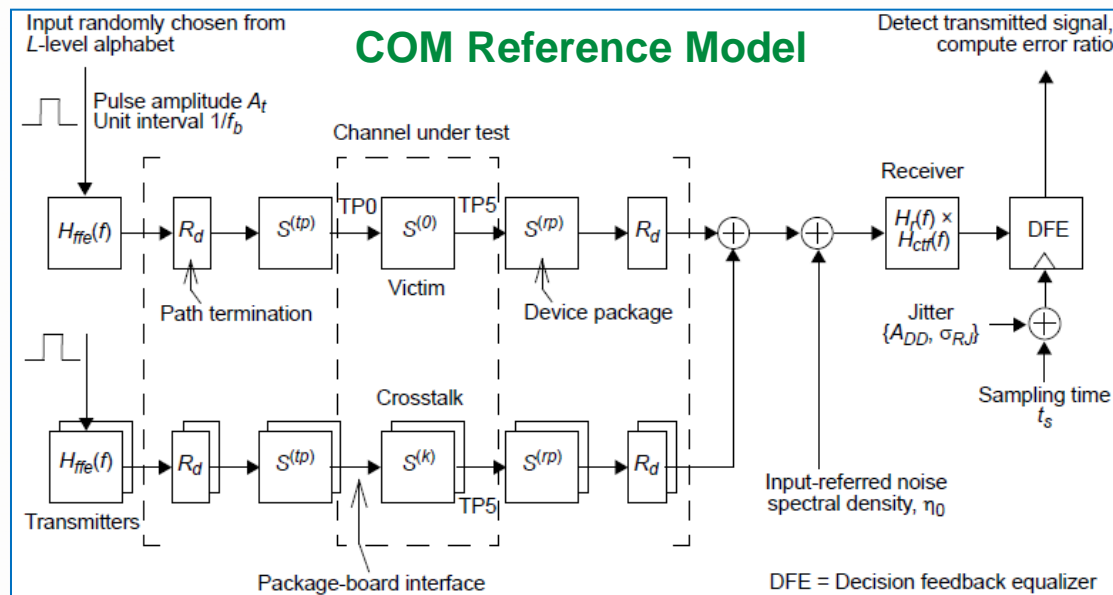

# COM Basic Assumptions

Usually the following assumptions are made in computing COM:

- Crosstalk aggressors:
  - 0.4Vpd with FFE is assumed for the FEXT stimuli
  - 0.6Vpd without FFE is assumed for the NEXT stimuli
- Jitter:
  - TX Jitter (dual-Dirac and RJ RMS) is converted to noise according to the slope of the impulse response (after CTLE)
- Residual ISI:
  - ILD caused ripples may not be captured
- Noise assumption when relating to certain  $DER_0$ :

$$FOM = 10 \log_{10} \left( \frac{A_s^2}{\sigma_{TX}^2 + \sigma_{ISI}^2 + \sigma_J^2 + \sigma_{XT}^2 + \sigma_N^2} \right)$$



# COM Computation Steps

## Step1: Constructing 'channel' voltage transfer function

- Channel is the cascaded S-parameter of the passive channel (victim and aggressor paths), the packages, the TX FFE (with exception of the NEXT), and the RX CTLE filter.
- SBR (single bit response) of each path, including the through and crosstalk channels, is calculated accordingly.

## Step2: Determining the 'optimal' equalizer parameters

- TX FFE tap coefficients, RX CTLE DC gain, and main cursor sampling point  $t_s$ , etc. are computed based on exhaustive search such that the combined solution space delivers the best FOM.

## Step3: Calculating COM

- See the following slides for details.

# Channel TF Construction

- Cascaded channel

$$H^{(k)}(f) = H_{ffe}(f)H_{21}^{(k)}(f)H_r(f)H_{ctf}(f)$$

- Passive link

$$H_{21}(f) = \frac{s_{21}(f)(1 - \Gamma_1)(1 + \Gamma_2)}{1 - s_{11}(f)\Gamma_1(f) - s_{22}(f)\Gamma_2(f) + \Gamma_1(f)\Gamma_2(f)\Delta S(f)}$$

- TX FFE

$$H_{ffe}(f) = \sum_{i=-1}^1 c(i) \exp(-j2\pi(i+1)(f/f_b))$$

- For a NEXT path,  $c(-1)$  and  $c(1)$  are always 0
- $c(0)$  is normalized such that  $c(0) = 1 - |c(-1)| - |c(1)|$
- $c(-1)$  is in the range of  $[-0.18 : 0.02 : 0]$
- $c(1)$  is in the range of  $[-0.38 : 0.02 : 0]$

# Channel TF Construction (Cont'd)

- RX noise filter

$$H_r(f) = \frac{1}{1 - 3.414214(f/f_r)^2 + (f/f_r)^4 + j2.613126(f/f_r - (f/f_r)^3)}$$

- RX CTLE equalizer

$$H_{CTLE}(f) = f_b \frac{j \cdot f + 0.25 \cdot f_b 10^{\frac{G_{DC}}{20}}}{(j \cdot f + 0.25 \cdot f_b) \cdot (j \cdot f + f_b)}$$

$G_{DC}$  is in dB. It covers an range of -12dB to 0dB.

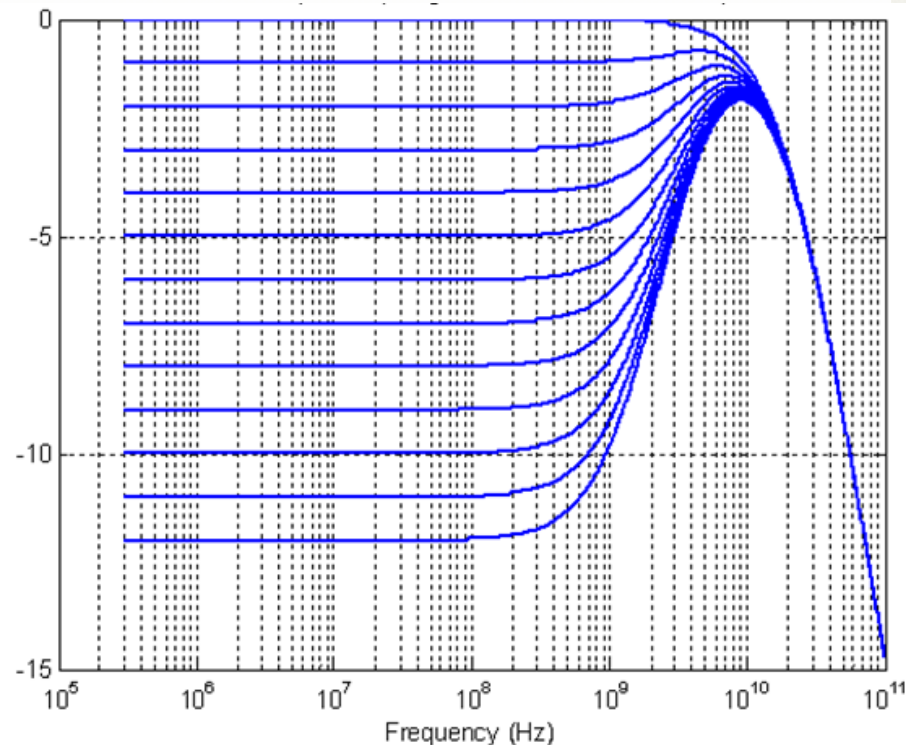



# Coefficients Determination

To determine parameters of  $c(-1)$ ,  $c(1)$  and  $g_{DC}$ , we do the following:

1. For a given set of the coefficients, compute the SBR,  $h^{(k)}(t)$ , of victim path and crosstalk paths;
2. Determine the sampling point  $t_s$ . The main cursor sampling point is assumed 1UI after the 1st positive zero crossing.

$$h^{(0)}(t_s - T_b) = h^{(0)}(t_s + T_b) - h^{(0)}(t_s)b(1)$$

3. DFE coefficients are calculated by

$$b(n) = \left\{ \begin{array}{ll} -b_{\max}(n) & h^{(0)}(t_s + nT_b)/h^{(0)}(t_s) < -b_{\max}(n) \\ b_{\max}(n) & h^{(0)}(t_s + nT_b)/h^{(0)}(t_s) > b_{\max}(n) \\ h^{(0)}(t_s + nT_b)/h^{(0)}(t_s) & \text{otherwise} \end{array} \right\}$$

# Coefficients Determination (Con't)

## 4. Calculate Noise:

1) Transmitter output noise (by default  $\text{SNR}_{\text{TX}}=27\text{dB}$ ):

$$\sigma_{\text{TX}}^2 = \sigma_X^2 (A_s / R_{\text{LM}})^2 10^{-\text{SNR}_{\text{TX}}/10}$$

2) Residual ISI (after DFE) amplitude variance:

$$\sigma_{\text{ISI}}^2 = \sigma_X^2 \sum_n h_{\text{ISI}}^2(n) \quad h_{\text{ISI}}(n) = \left\{ \begin{array}{ll} 0 & n = 0 \\ h^{(0)}(t_s + nT_b) - h^{(0)}(t_s)b(n) & 1 \leq n \leq N_b \\ h^{(0)}(t_s + nT_b) & \text{otherwise} \end{array} \right\}$$

3) Variance of the amplitude error due to jitter:

$$\sigma_J^2 = (A_{\text{DD}}^2 + \sigma_{\text{RJ}}^2) \sigma_X^2 \sum_n h_J^2(n)$$

where,  $h_J(n)$  represents the “slope”.

# Coefficients Determination (Con't)

4) Sum of the maximum variances for all K-1 crosstalk paths:

$$\sigma_{XT}^2 = \sum_{k=1}^{K-1} [\sigma_i^{(k)}]^2 \quad [\sigma_m^{(k)}]^2 = \sigma_X^2 \sum_n [h^{(k)}((m/M + n)T_b)]^2$$

where, the value of  $m$  that maximizes the variance for each path  $k$  is denoted as  $i$ .

5) Variance of the noise at the output of CTLE:

$$\sigma_N^2 = \eta_0 \int_0^{\infty} |H_r(f)H_{ctf}(f)|^2 df$$

where, the value  $\eta_0$  is the one-sided spectral density, by default  $5.2e-8 \text{ V}^2/\text{GHz}$

5. Calculate FOM:

$$FOM = 10 \log_{10} \left( \frac{A_s^2}{\sigma_{TX}^2 + \sigma_{ISI}^2 + \sigma_J^2 + \sigma_{XT}^2 + \sigma_N^2} \right)$$



# COM Computation

The combination of values (ts, FFE coefficients, DC Gain) that maximized the FOM is used to compute COM.

a) Interference and noise amplitude calculation:

$$p(y) = p(y) * p^{(k)}(y)$$

Convolution of residual ISI distribution  $p(y)$  with all the crosstalk noise distribution  $p^{(k)}(y)$

b) Noise amplitude distribution:

$$p_n(y) = p_G(y) * p_{DD}(y)$$

Convolution of Gaussian noise (TX output noise  $\sigma_{TX}^2$ , RJ induced noise, and noise at the output of the RX equalizer  $\sigma_N^2$ ), with amplitude noise resulting from dual-Dirac jitter.

c) The combined interference and noise amplitude distribution:  
convolving a) and b) distributions and the symbol distribution.

- The total distribution from c) is then used for CDF integration, and the  $A_{ni}$  used for COM calculation, is the amplitude of the value that satisfies the  $DER_0$ :  $COM = 20 * \log_{10}(A_s / A_{ni})$



# COM Computation of Case-Study Channels

# Link Channels for Case Study

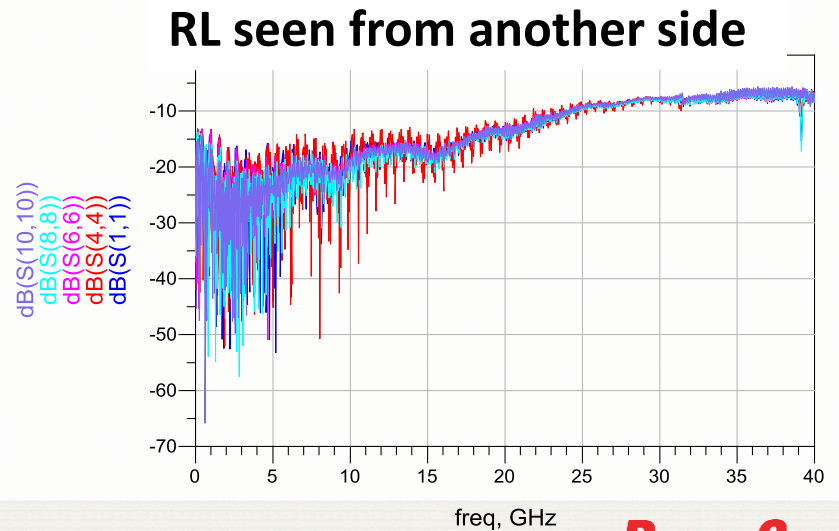
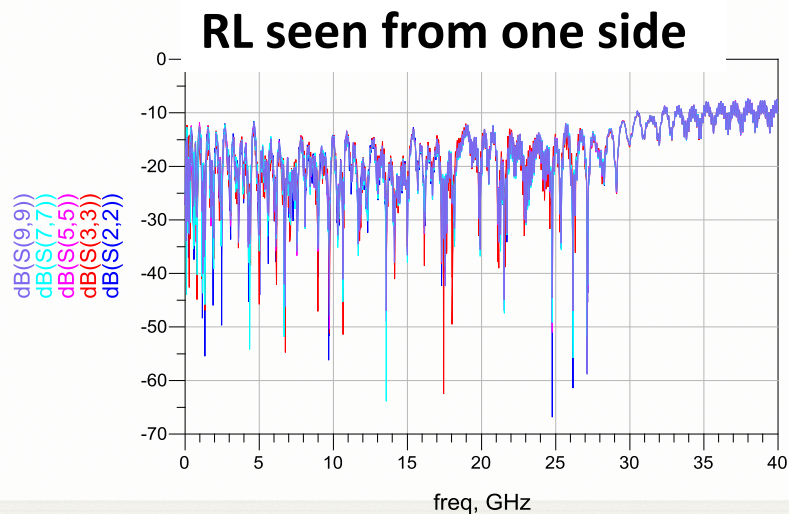
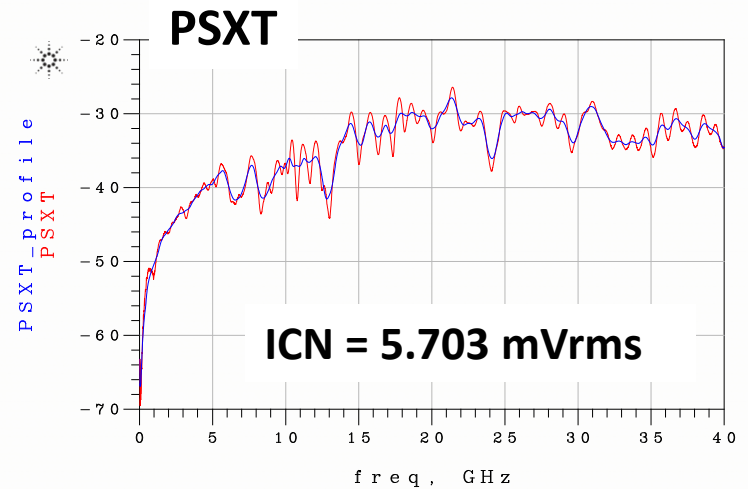
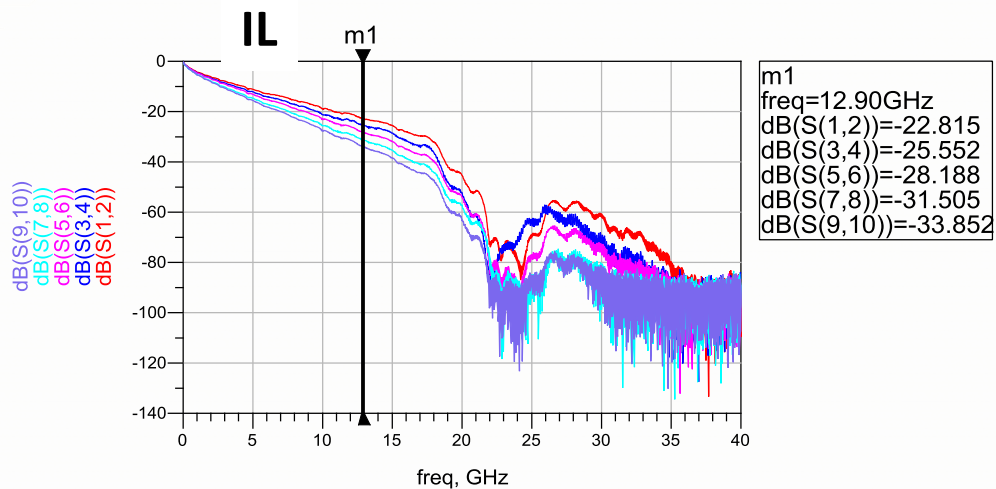



# Computed COM for 5 Links

- $DER_0$  is set to  $1e-15$  for the computation

COM (dB)	Link #1	Link #2	Link #3	Link #4	Link #5
Link Loss	22.8	25.6	28.2	31.5	33.9
w/o Crosstalk	5.00	4.32	3.99	3.18	2.55
w/ Crosstalk	-0.86	-2.27	-3.20	-4.94	-5.95
Degradation	5.86	6.59	7.19	8.12	8.50

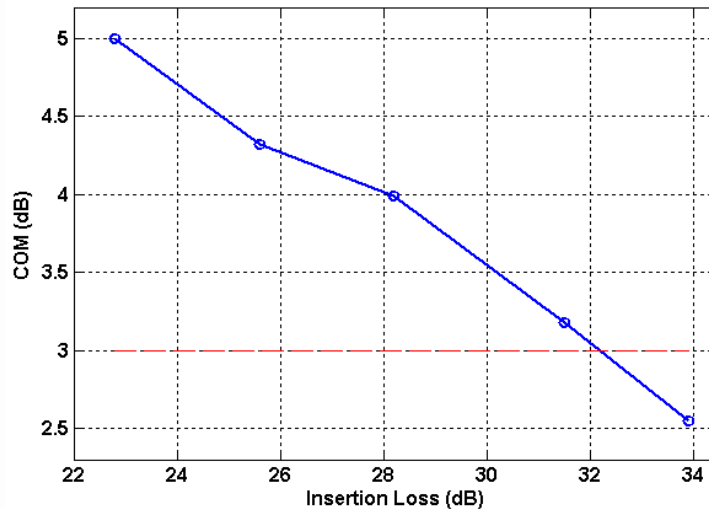

COM w/o Crosstalk

# Computed COM Observations

- When no crosstalk is included, links 1-4 passed ( $>3\text{dB}$  margin), while link 5 failed
- When all 8-aggressor crosstalk is added, all links failed ( $\ll 3\text{dB}$ )
- In general, the smaller the COM without crosstalk, the faster degradation in COM when crosstalk is included
- COM is usually more friendly with low-loss channels, as long as RL is within control. (In reality, this is not always true.)
- Even without crosstalk, COM failed for a channel whose  $IL < 34\text{dB}$ 
  - This channel (and even some more lossy channels) easily runs error free with a couple devices by mid 2013.
  - This shows that COM could be more on the conservative side comparing with best available devices out there. For example, even for  $25\text{dB}$  loss channel, there was only  $1.3\text{dB}$  margin above  $3\text{dB}$  line.



# TD Link Simulation of Case-Study Channels



# Simulation Setup for Models A & B

- Common in features, but not in implementations
  - Data rate = 25Gbps
  - RX adaptive CTLE + AGC + 15-tap DFE
  - Baseline wander adaptive cancellation
  - Bang-bang CDR, with data sampling phase auto-adjusting
  - TX launch amplitude = 1Vdpp, rise/fall time ~15ps
  - Data pattern = PRBS-23, and simulated bits = 5 M
  - Target BER < 1E-15, without FEC
- Different in features
  - Model A: TX 4-tap adaptive FFE
  - Model B: TX 3-tap programmable FFE

# Model-A Simulation Results

Link Setup	EW (UI)	EW (mVpd)	BER Floor	Optimized TX FFE
Thru #1 only	28.3	35.5	3.6e-66	[1.632e-2, -1.625e-1, 8.159e-1, -5.286e-3]
Thru #1 + XT	16.4	18.2	5.5e-36	[1.388e-2, -1.556e-1, 8.227e-1, 7.843e-3]
Thru #2 only	20.9	29.7	6.5e-48	[1.718e-2, -1.655e-1, 8.112e-1, -6.085e-3]
Thru #2 + XT	3.20	4.07	1.3e-18	[1.874e-2, -1.647e-1, 8.113e-1, -5.290e-3]
Thru #3 only	21.5	29.3	4.7e-46	[1.650e-2, -1.635e-1, 8.178e-1, 2.259e-3]
Thru #3 + XT	0.0	0.0	2.5e-9	[1.755e-2, -1.668e-1, 8.155e-1, -1.376e-4]
Thru #4 only	19.1	22.4	5.8e-37	[1.796e-2, -1.778e-1, 8.021e-1, -2.193e-3]
Thru #4 + XT	0.0	0.0	6.1e-6	[2.336e-2, -1.781e-1, 7.943e-1, 4.273e-3]
Thru #5 only	17.5	19.8	5.5e-33	[2.643e-2, -1.925e-1, 7.752e-1, 5.922e-3]
Thru #5 + XT	0.0	0.0	5.3e-5	[2.474e-2, -1.845e-1, 7.783e-1, 1.248e-2]

- Note 1: EW (eye width) and EH (eye height) are measured at BER=1e-15.
- Note 2: TX FFE settings might be different with and without crosstalk.

# TX Setting Comparison (informative)

- TX FFE settings from Model-A (adaptively determined) and COM (computed) are compared below.

Link Setup	TX FFE from COM	TX FFE from Model-A
<b>Thru #1</b>	[-0.140, 0.860, 0.000]	[0.0163, -0.1625, 0.8159, -0.0053]
<b>Thru #2</b>	[-0.140, 0.840, -0.020]	[0.0172, -0.1655, 0.8112, -0.0061]
<b>Thru #3</b>	[-0.140, 0.820, -0.040]	[0.0165, -0.1635, 0.8178, 0.0022]
<b>Thru #4</b>	[-0.120, 0.760, -0.120]	[0.0179, -0.1778, 0.8021, -0.0022]
<b>Thru #5</b>	[-0.120, 0.760, -0.120]	[0.0263, -0.1925, 0.7752, 0.0060]



# Model-B Simulation Results

- Same TX DE,  $\{-0.075, 0.75, -0.175\}$ , is applied to all cases.
- When no crosstalk is applied

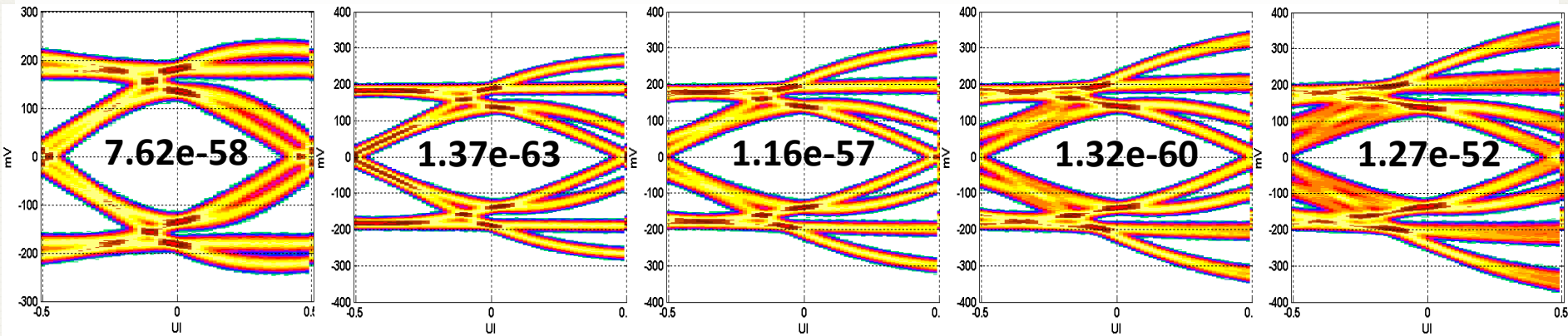

- When crosstalk is added

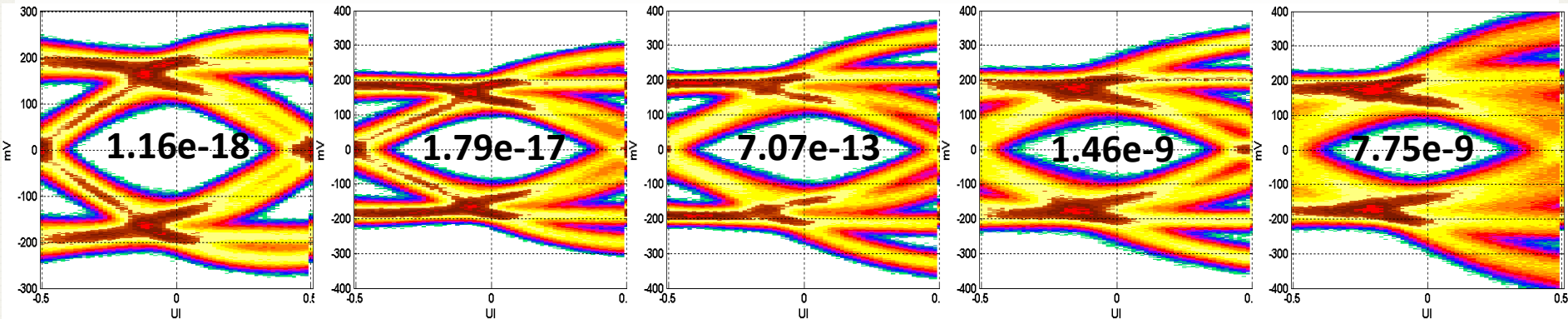

# Comparing COM with Simulations (1)

- We first convert BER to SNR by the simplified model:

$$\text{BER} \cong 0.5 \cdot \text{erfc}\left(\frac{\sqrt{\text{SNR}}}{\sqrt{2}}\right)$$

- For BER=1e-15, we subtract the simulated SNR at data sampler by 18dB. We also allow 3dB for impairments that are not accounted for in the model.
- The computed COM at BER=1e-15 is compared with 3dB threshold to check link pass/fail.
- From the next slide it is seen that time domain device model simulations and COM agree pretty well in trend for all cases.
  - There are some differences in details, which could be as much as several dB.
  - It is known that device model simulations are usually on the more conservative side, which implies that COM could also be more conservative. However, this does not affect COM validity as a link perform FOM.

# Comparing COM with Simulations (2)

Without Crosstalk

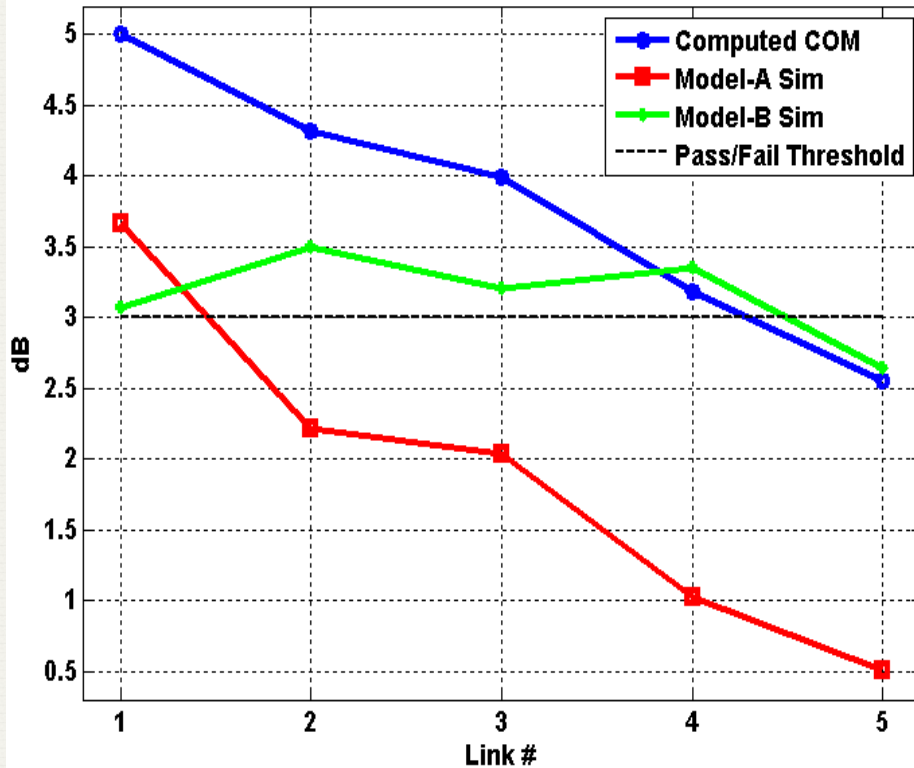

With Crosstalk

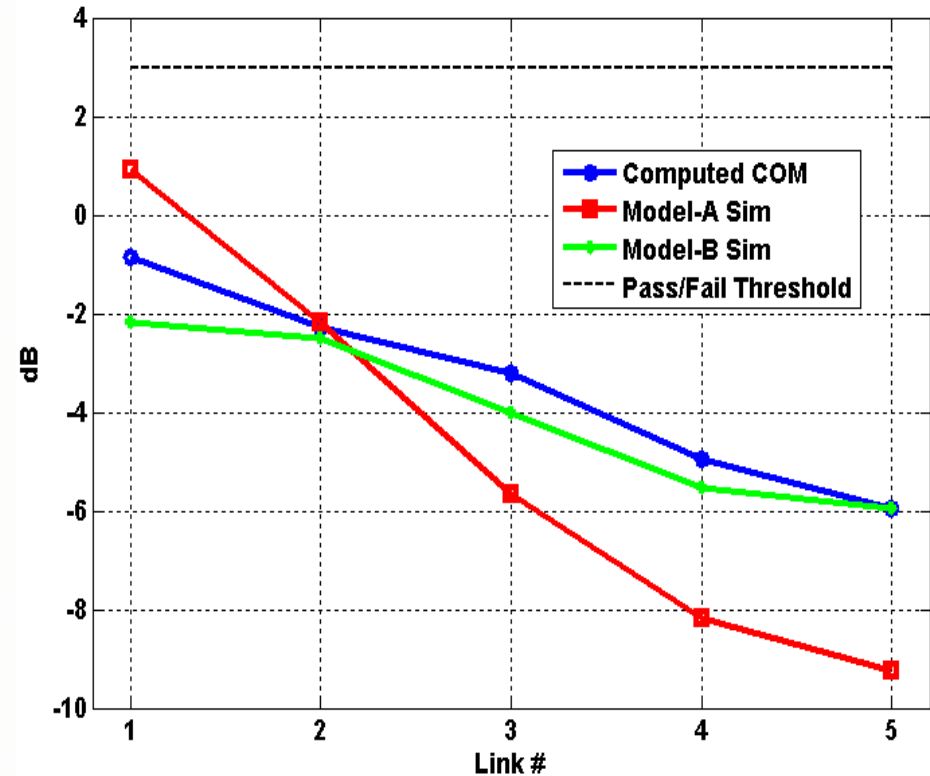





# 25G Experimental Data And Justification of Simulation Models

# Hardware Test

- A 28G NRZ SerDes device was run at 25.78125Gbps. The performance of this device is represented by Model-A.

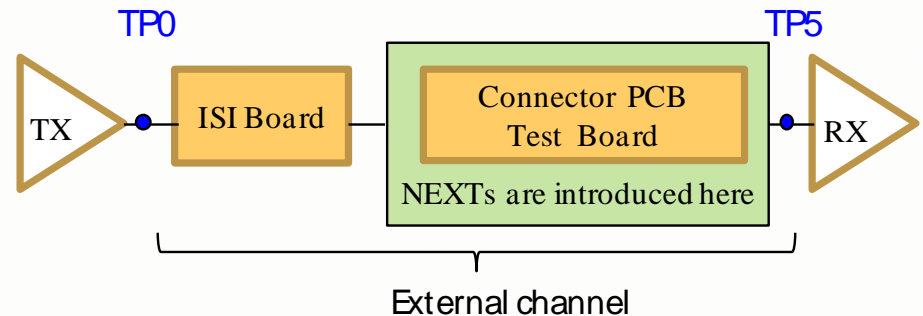

- All 4 cases were running error free for at least 11 hours
  - System noise is always present even when no crosstalk is applied;
  - It is seen the channel loss at 38dB (without considering package losses) the system was running error free

Setup	IL @ Nyquist	ICN	Test time
25.78125Gbps PRBS31 Pattern	26.2 dB	2.8 mV	> 12hrs
	29.9 dB	1.8 mV	> 12hrs
	32.5 dB	1.2 mV	> 12hrs
	38 dB	0 (no XT)	> 11hrs

# Simulation Results

- Adjusting the crosstalk amount by changing aggressor stimuli:

Channel Setup			TD Simulation (BER=1e-15)			COM (dB)
Setup	IL	ICN	EW(UI)	EH (mVpd)	BER Floor	
Thru-#2 +XTK	25.5dB	2.78mV	0.174	21.7	7.9e-38	0.996
Thru-#5 +XTK	31.5dB	1.82mV	0.113	14.3	1.7e-23	0.483
Thru only (no XT)	38.4dB	0mV	0.203	19.9	1.2e-32	0.655

- The passing/failing criterion is set to **EH>20mVpd** and **EW>0.15UI**, margin for implementation penalty.
- The simulated results correlate with lab test data in the ball park of desired BER.
  - The general observation from many lab tests and simulations is that simulation is more on the conservative side.
  - BER test is essentially statistical in nature, and exact correction is hard.





# Individual Factors Affecting COM

# Individual Factors Affecting COM

- Here we compute COM based on one single factor so that we can see the individual impact on the final COM more directly.
  - It is really impossible to separate impacting factors, and we are trying to seek the trend.
- We simulate a set of s-parameters for this purpose. All files covers a frequency range up to 50GHz.
  - 8 insertion loss profiles whose IL are approximately 10dB to 45dB at 12.5GHz, while the RL is maintained at around -20dB
  - 4 return loss profiles cover RL from -5dB to -20dB.
  - 5 crosstalk profiles with PSXT around -25dB to -45dB.
- The computed COM is summarized in 2-D plots below.

# COM(IL, RL): ICN = $0mV_{rms}$

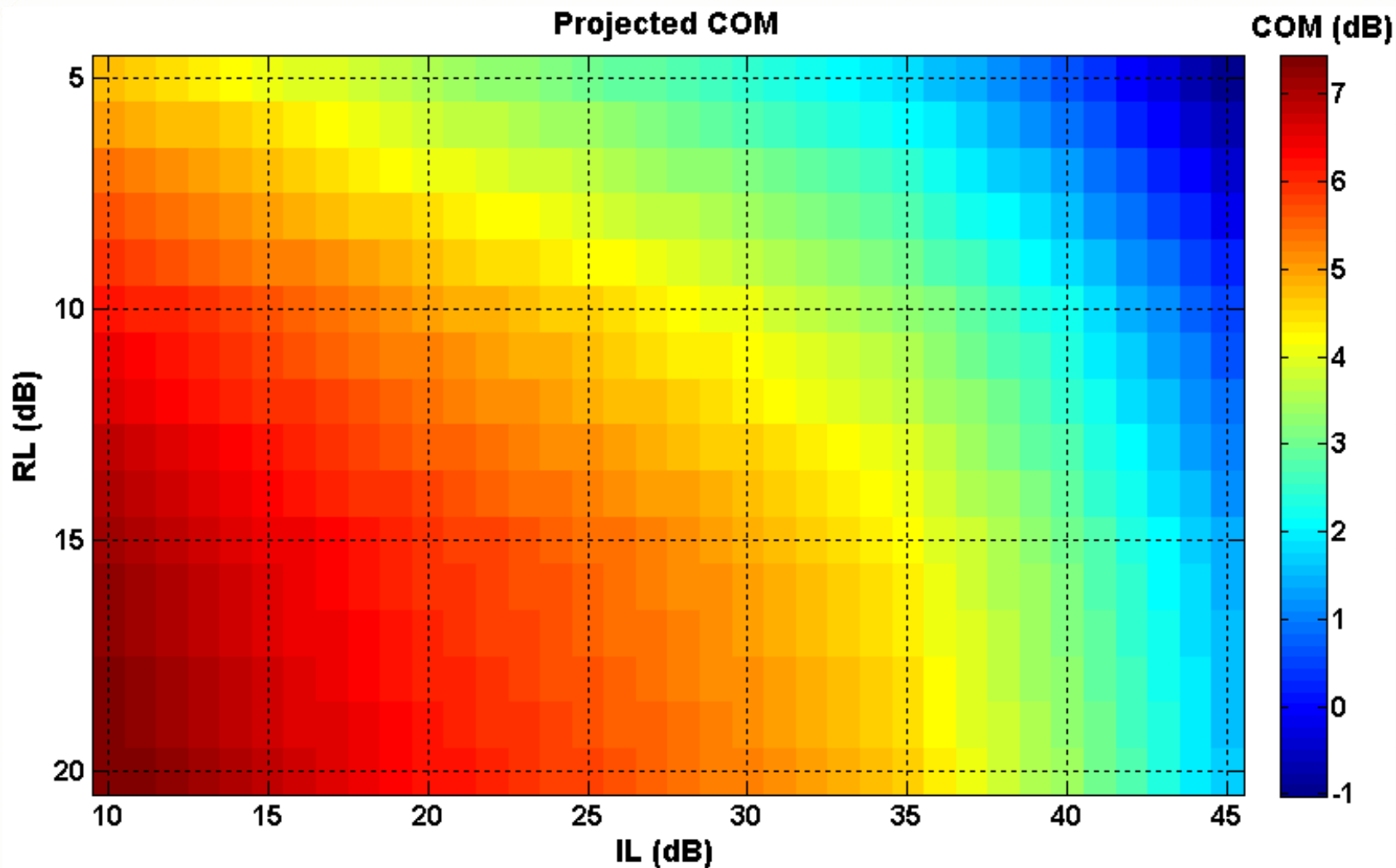



# COM(IL, XT): $RL \approx 20dB$

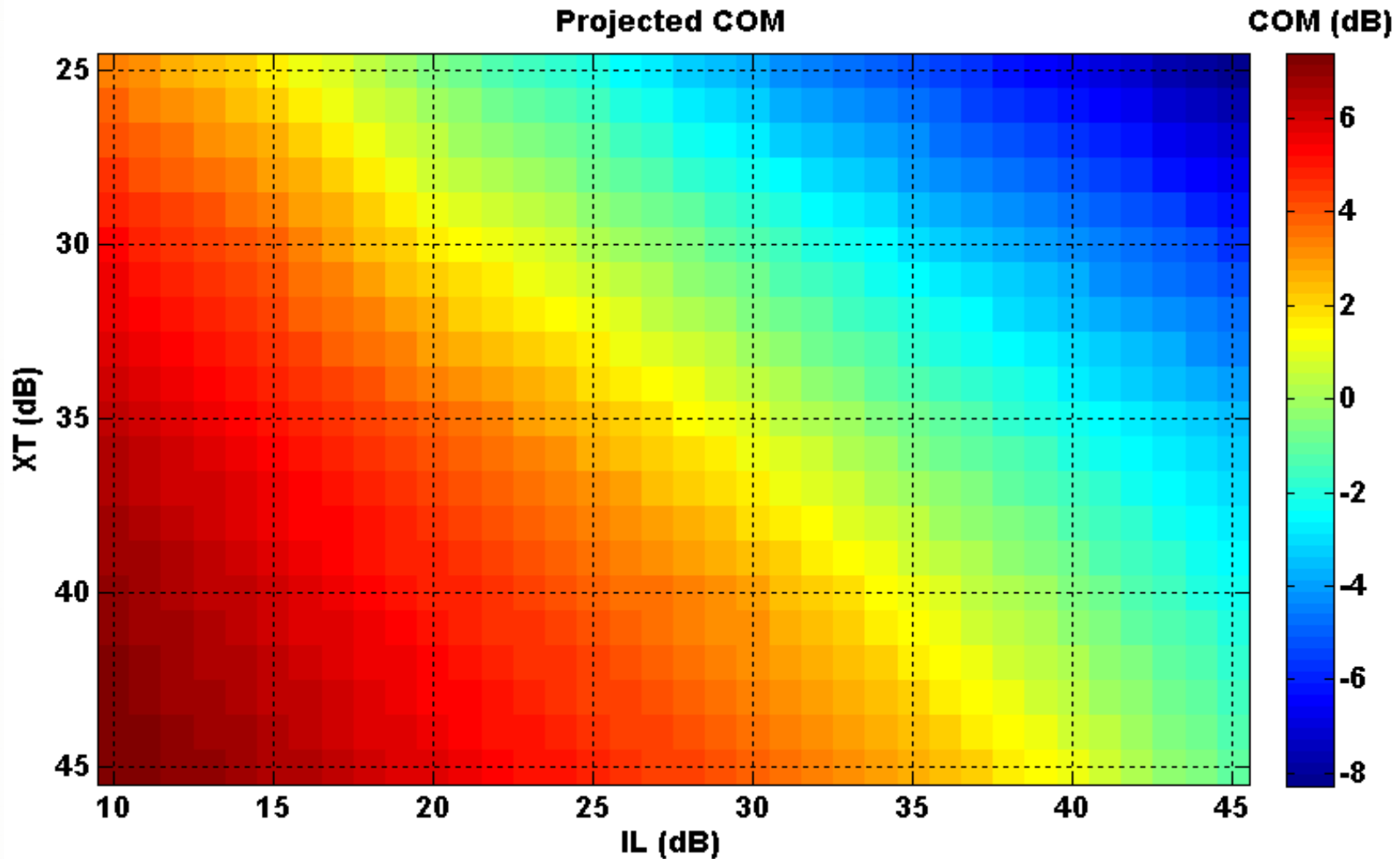

# PSXT Vs. ICN

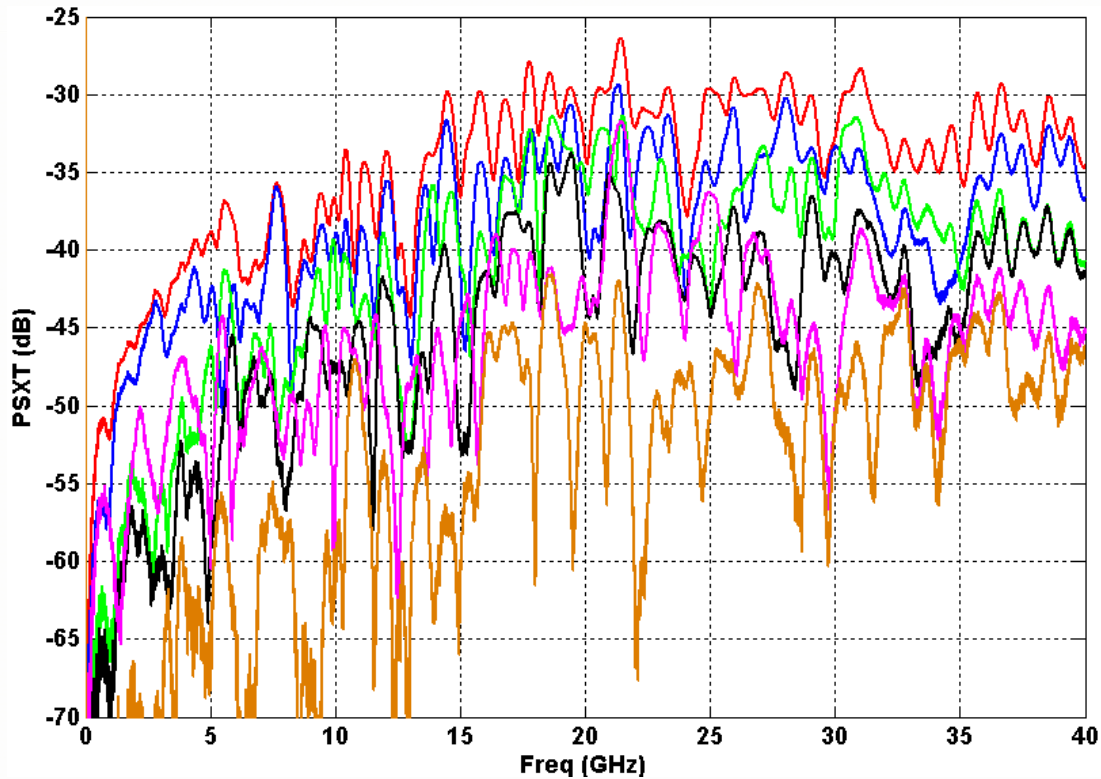

ICN (mVrms)

5.70

4.05

2.77

1.79

1.66

0.65

- For today's 25Gbps systems,  $ICN < 2mV$  is considered as good.
- For  $ICN > 4mV$ , IL should generally be constrained to within 25dB.



# Proposed Simplified Channel Specs for 25G



# COM is a Useful FOM

- From the above analysis, we see that COM can provide a general guideline for system and interconnect engineers.
  - COM tracks two real device simulation results in trend.
- However, COM is not intuitive and not straightforward to use during early stages of product definition.
- As a result, we propose a simple channel template that is not only easy to use to relate performance to channel parameters, but also works well for initial system architecture purpose.
  - COM can be used as a double check of the architected system;
  - Time domain simulations are used at a later stage once the selection of SerDes IP is narrowed down.

# Proposed Channel Templates

- This template is for mid-level performers, without FEC.
- For stronger SerDes IPs constraints can be relaxed accordingly.
- Worst case S-parameters should be used, for example, at high temperature.

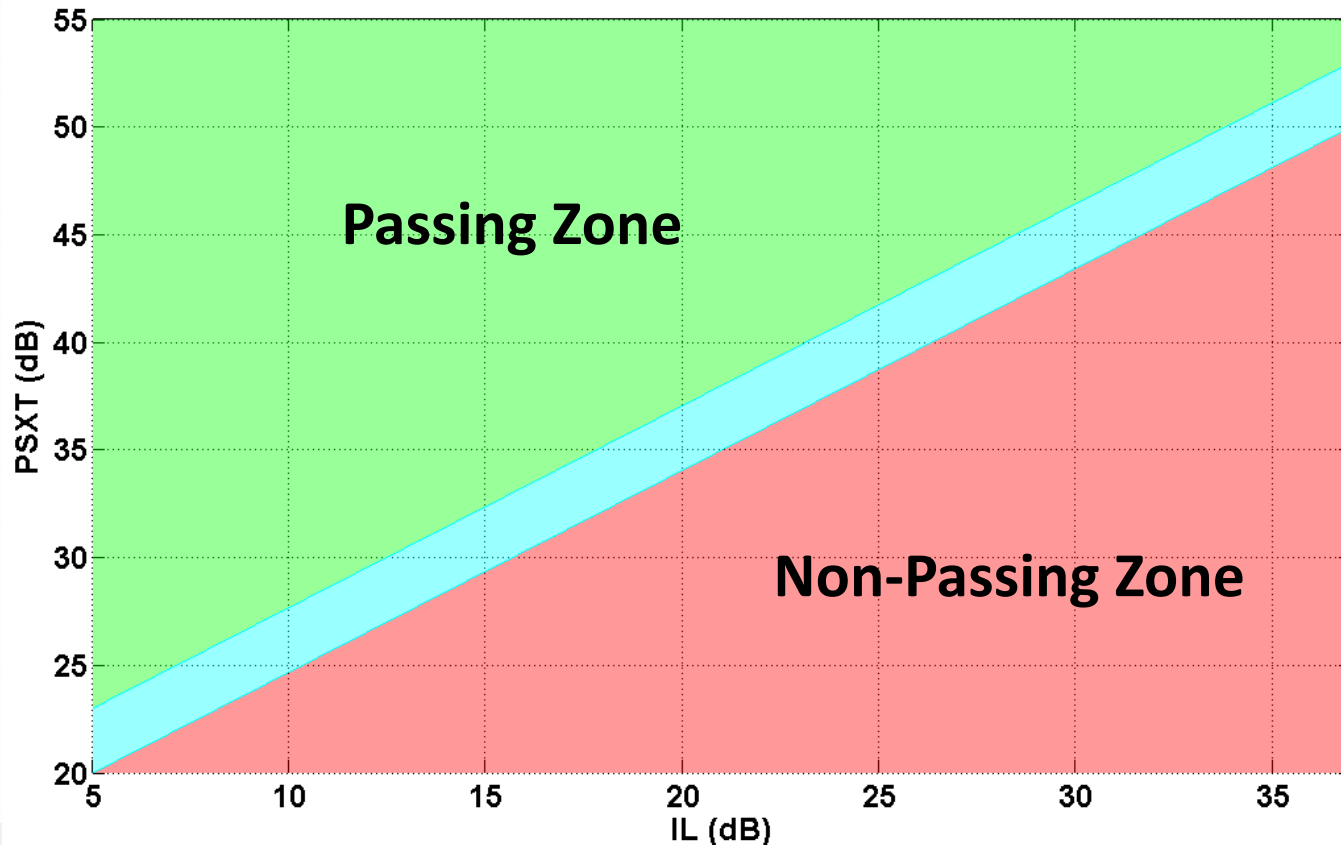

# Conclusions

- We have introduced IEEE802.3bj proposed COM as a FOM for 25G system analysis
- We have shown that COM can provide a general guideline for 25G system passive link design
  - COM basically correlates with time-domain simulations.
  - Lab test shows that simulation result is supported.
  - COM is slightly on the more conservative side, as TD simulation.
- However, COM is not straightforward to use for system engineers. Thus we have proposed a simple template
  - The template can be easily referenced during system definition.
  - COM can be used once product architecture is finalized.
  - Model simulation can be used when device selection is narrow down.
  - Hardware test is essentially the ultimate proof of a successful design.



# References

- [1] IEEE Std 802.3ap-2007
- [2] <http://www.oiforum.com/>
- [3] <http://www.ieee802.org/3/bj/>
- [4] Richard Mellitz, et al, “ Channel Operating Margin (COM): Evolution of Channel Specifications for 25 Gbps and Beyond”, DesignCon 2013.
- [5] Richard Mellitz, “Channel Operating Margin Program Usage”, February 08, 2013, IEEE802.3bj, Phoenix, AZ Interim.
- [6] Beth Kochuparambil, “802.3bj Channel Evaluation with COM”, IEEE 802.3bm Interim - September 2013, York, England.
- [7] Adee Ran and Richard Mellitz, “Analysis of contributed channels using the COM method”, IEEE 802.3bj Task Force July 2012

# References (Con't)

- [8] Nathan Tracy and Megha Shanbhag, “Backplane Channels Using Embedded Capacitor Connectors as an Enabler for 400GE 40” System Measurements”, July 2013 Plenary, Geneva, Switzerland
- [9] COMPAL ELECTRONICS, INC. Taipei Server Business, “Channel Based Methods for Signal Integrity Evaluation”, Aug 13, 2013
- [10] Charles Moore and Adam Healey, “A method for evaluating channels”, 100 Gb/s Backplane and Copper Study Group, Singapore, March 2011
- [11] A. Vareljian and H. Takatori , “Channel Qualification Based on Salz”, IEEE 802.3bj Task Force, Sep 2012